

INDOOR COILS

R-410A
featuring
 earth friendly refrigerant



Rheem
Prestige[®]
 SERIES

RCQD- SUPER HIGH EFFICIENCY INDOOR COILS

AIRFLOW CAPACITIES
450-1600 CFM
[212-755 L/s]

Rheem Prestige Series[®] Indoor Coils are designed for use with Rheem outdoor units and are available for vertical upflow, horizontal left or horizontal right airflow. When matched with Rheem outdoor units, the coils provide a capacity range from 24,000 BTU/HR [7.04 kW] to 48,000 BTU/HR [14.0 kW].

- Constructed of aluminum fins bonded to intergrooved copper tubing.
- Coils are tested at the factory with an extensive refrigerant leak check for improved quality control.
- Coils have sweat fitting refrigerant connections.
- Ideally suited for new installations or add on air conditioning.
- Condensate drain connections are 3/4" [19.1 mm] N.P.T. for ease of connection.
- Coils are A.R.I. certified for system application with variety of Rheem outdoor units.
- Condensate drain pan is constructed of high grade, heat resistant, corrosion free thermal-setting material.
- Compatible with Germicidal Light System

c **UL** **us**
LISTED

MODEL NUMBER DATA

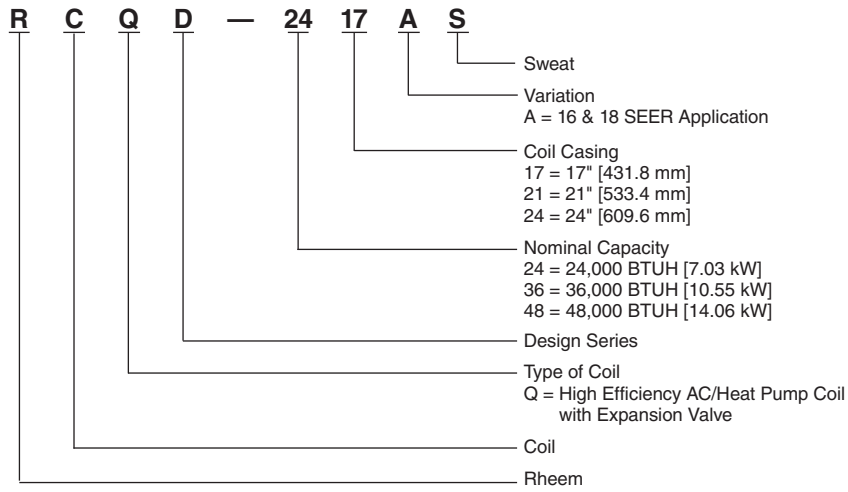

Coil Specifications/Airflow Pressure Drop

Model Number RCQD-	Type Air Flow ①	Approx. Design Air Flow CFM [L/s] Range	Face Area Sq. Ft. [m ²]	Fins-in. Rows Deep	Static Pressure Drop Through Wet Cooling Coil [kPa] (Inches H ₂ O) CFM [L/s]													
					600 [285]	700 [330]	800 [380]	900 [425]	1000 [470]	1100 [519]	1200 [565]	1300 [614]	1400 [660]	1500 [708]	1600 [755]	1700 [802]	1800 [850]	1900 [897]
HIGH EFFICIENCY COOLING COILS																		
2417AS	U-H	450/800 [212/378]	4.38 [0.41]	14/3	.06 [.025]	.10 [.025]	.14 [.035]	.17 [.042]	.21 [.052]	.25 [.062]	.29 [.072]							
3621AS	U-H	720/1200 [340/566]	5.83 [0.54]	14/3			.08 [.020]	.10 [.025]	.13 [.032]	.16 [.040]	.18 [.045]	.21 [.052]						
3624AS	U-H	720/1200 [340/566]	5.83 [0.54]	14/3			.07 [.017]	.09 [.022]	.11 [.027]	.13 [.032]	.15 [.037]	.17 [.042]						
4821AS	U-H	960/1600 [453/755]	5.83 [0.54]	14/3					.14 [.035]	.17 [.042]	.19 [.047]	.22 [.055]	.25 [.062]	.29 [.072]	.32 [.080]			
4824AS	U-H	960/1600 [453/755]	5.83 [0.54]	14/3					.11 [.027]	.13 [.032]	.15 [.037]	.17 [.042]	.19 [.047]	.23 [.057]	.25 [.062]			

① H = Horizontal airflow, U = Upflow

Coil Application (No Downflow Applications)

Coils can be matched to heating products as listed in table below.

Coil Model RCQD-	Type Air Flow*	Furnace Width (In.) (mm)		Plenum Adapter Upflow
		Oil	Gas	
2417AS	U-H	21 [533]	17 1/2 [444]	N/A
	U-H		14 [356]	RXBA-AC
3621AS	U-H	21 [533]		N/A
	U-H		21 [533]	N/A
	U-H		17 1/2 [445]	RXBA-AC
4821AS	U-H		21 [533]	N/A
	U-H		17 1/2 [445]	RXBA-AC
3624AS 4824AS	U-H	24 1/2 [622]		N/A
	U-H		24 1/2 [622]	N/A
	U-H		21 [533]	RXBA-AC

*Notes: U = Upflow
H = Horizontal

Coil Dimensions and Weights

Coil Model Number	Connections		Dimensions (In.) [mm]-Weight (lbs.) [Kg]				
	Sweat (in.) [mm]		A	B	C	Coil Weight (lbs.) [Kg.]	Shipping Weight (lbs.) [Kg.]
	Liquid	Suction					
	I.D.	I.D.					
RCQD-2417AS	3/8 [9.53]	3/4 [19.05]	17 1/2 [445]	19 7/8 [505]	28 [711]	59 [27]	67 [38]
RCQD-3621AS	3/8 [9.53]	7/8 [22.23]	21 [533]	24 3/4 [629]	28 [711]	74 [34]	83 [38]
RCQD-3624AS	3/8 [9.53]	7/8 [22.23]	24 1/2 [622]	24 3/4 [629]	28 [711]	80 [36]	90 [41]
RCQD-4821AS	3/8 [9.53]	7/8 [22.23]	21 [533]	24 3/4 [629]	28 [711]	74 [34]	83 [38]
RCQD-4824AS	3/8 [9.53]	7/8 [22.23]	24 1/2 [622]	24 3/4 [629]	28 [711]	80 [36]	90 [41]

[] Designates Metric Conversions

FRONT VIEW

SIDE VIEW

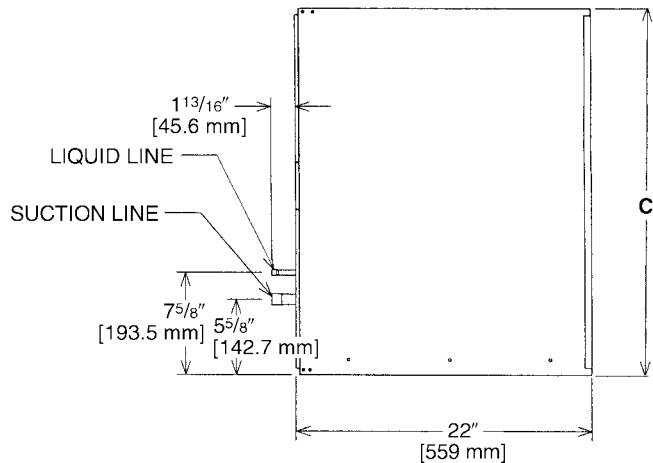
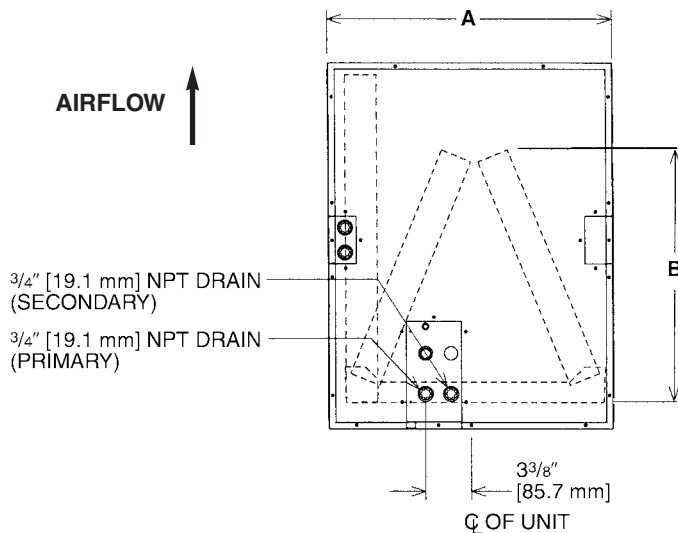

[] Designates Metric Conversions

Accessories

PLENUM ADAPTER ACCESSORY RXBA-AC

This plenum adapter accessory is for installation on cased indoor cooling and heat pump coils. This allows a nominal size cased coil to be installed on the next smaller size gas or oil furnace. **NOTE: This accessory is for installation on coil casings to fit gas or oil furnaces only – this accessory must not be used on electric furnaces or heat pump air handlers.** Consult the installation instructions packaged with the accessory for proper installation. The RXBA-AC (upflow) can be ordered factory installed by designation as "with adapters" in the coil model number.

PLENUM ADAPTER ACCESSORY RXBA-AE

This plenum adapter accessory is for use with the 24 $\frac{1}{2}$ " wide cased indoor cooling and heat pump coils. This allows a 24 $\frac{1}{2}$ " wide cased coil to be installed on a 28" wide oil furnace. This is a field installed accessory only.

PLENUM WIDTH

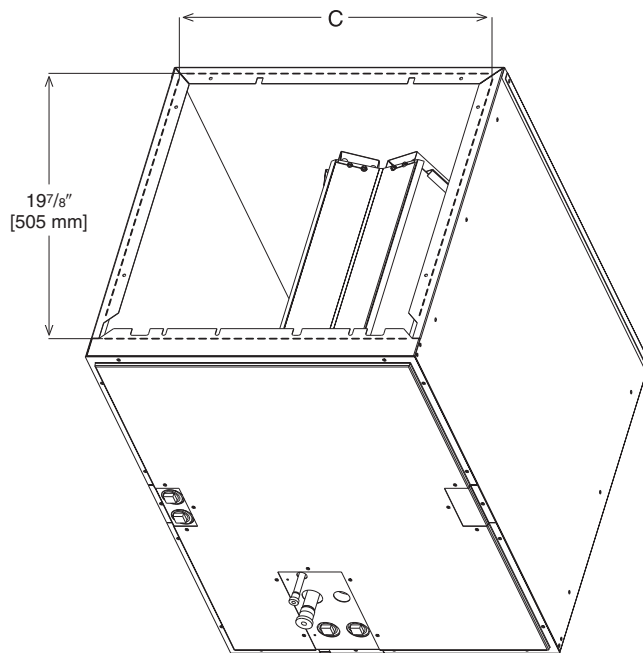

Before proceeding with installation, refer to installation instructions packaged with each model, as well as complying with all Federal, State, Provincial, and Local codes, regulations, and practices.

**RHEEM
AIR CONDITIONING
DIVISION**

5600 Old Greenwood Road, Fort Smith, Arkansas 72908



"In keeping with its policy of continuous progress and product improvement, Rheem reserves the right to make changes without notice."